

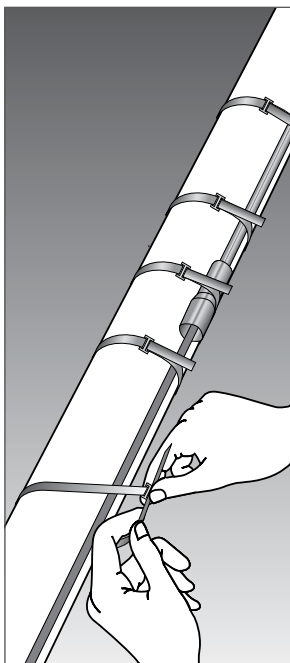

Raychem INSTALLATION, MAINTENANCE AND OPERATION MANUAL

MINERAL INSULATED (MI)
SERIES HEATING SYSTEMS



1	General information	4
2	Heating cable selection and storage	7
3	Heating cable installation	9
4	Components selection and installation	23
5	Temperature control and limitation	24
6	Thermal insulation and marking	27
7	Power supply and electrical protection	31
8	System testing	32
9	Operation, maintenance and repairs	33
10	Trouble Shooting	34
11	Installation Record Sheet	35

Typical configuration for MI-heating cable system (single conductor)

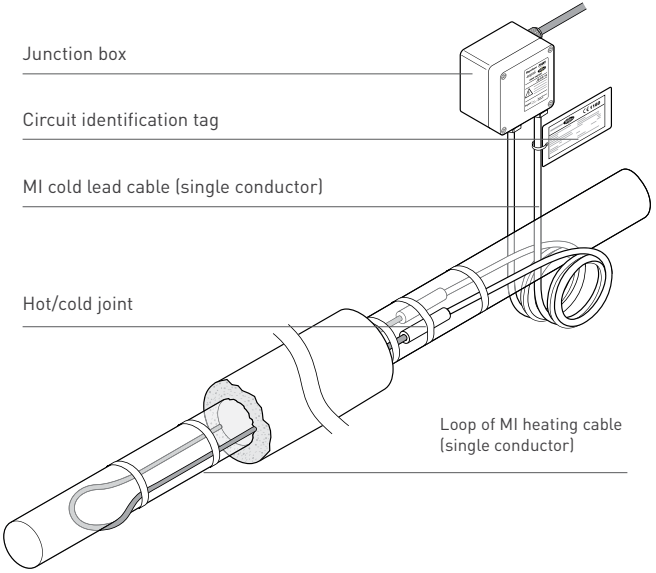

Typical configuration for MI-heating cable system (dual conductor)

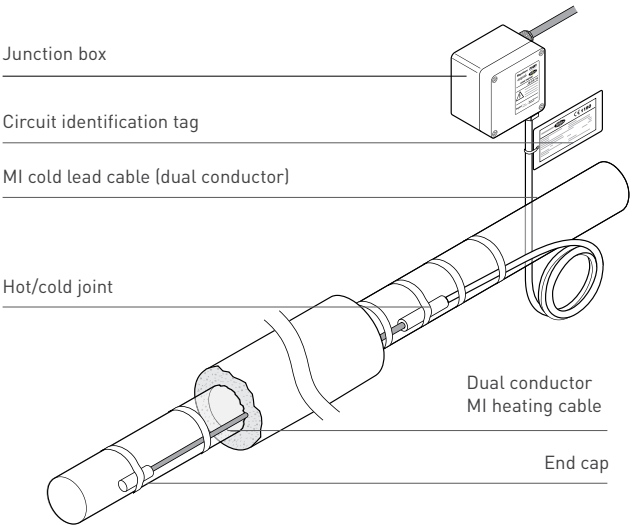

1 GENERAL INFORMATION

Use of the manual

This Installation and Maintenance manual applies to Pentair Thermal Management Mineral Insulated (MI) series resistance heating cable systems installed on thermally insulated pipes and vessels and associated equipment. In particular it refers to mineral insulated (MI) series heating systems, which feature a specific power output depending on various design parameters, in particular, cable length and voltage. This manual provides general information and shows an overview of the most common installations and applications on MI as well as typical examples. In any case the information provided for specific projects will take precedence over this manual. In case of conflicts, please contact your Pentair Thermal Management representative.

Pentair Thermal Management offers two different cable constructions for electrical heat-tracing purposes: single conductor cables, which are typically laid in loop configurations and dual conductor cables, which are typically laid in single runs.

Figure 1: Typical cable construction

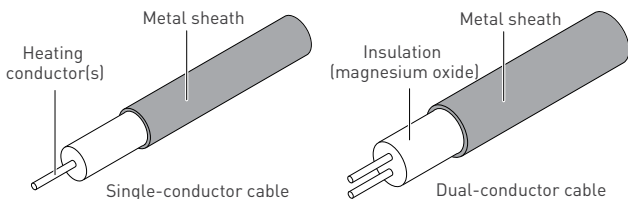

Various types of the MI bulk heating cables are available:

- HCC/HCH: Copper sheathed MI heating cables
- HDF/HDC: Cupro-nickel sheathed MI heating cables
- HSQ: Stainless steel sheathed MI heating cables
- HAX: Alloy 825 sheathed MI heating cables
- HIQ: Inconel sheathed MI heating cables

Figure 2: Typical heating unit designs

Design type B

Single conductor

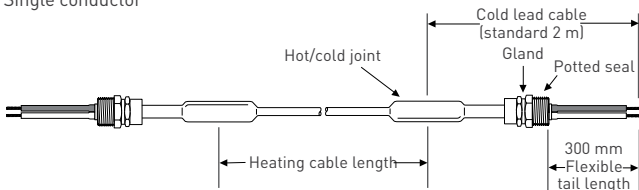

Design type D

Dual conductor

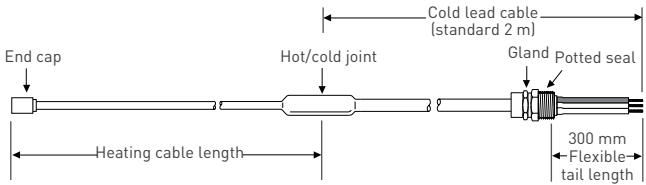

Design type E

Dual conductor

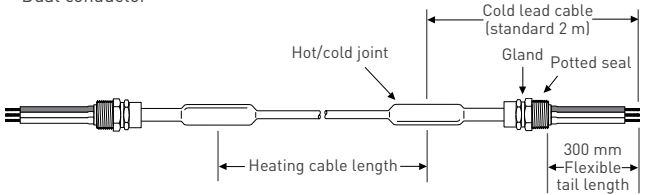

The joints can be either brazed or laser welded, refer to Pentair Thermal Management product literature for more detailed information.

Please note that this manual only covers the installation of pre-fabricated MI heating units. The complete termination process and repair of heating cable units is not covered by this manual and must be carried out by qualified and experienced personal only.

For more information contact your Pentair Thermal Management representative.

Important

For the Pentair Thermal Management warranty to apply, the instructions of this manual must be followed. Design, installation, inspection, operation and maintenance must be in accordance with the standards IEC 60519, IEC 62086, EN 50019 and EN60079-7 (where applicable). Other local requirements and national electric codes applicable to electrical heat-tracing systems must be followed as well. The thermal safety class is 2 (to IEC 60519-2).

Personal involved in the installation, testing and maintenance of electric heat-tracing systems must be suitably trained in all special techniques required, as well as in general electrical installation work. All work should be monitored by supervisors experienced in heat-tracing applications.

Area Classification – Ordinary

HCC/HCH/ HDC/HDF/HSQ/HAx/HIQ

Area Classification – Hazardous, Zone 1 or Zone 2

Special conditions for safe use in hazardous area:
Please refer to relevant hazardous area certifications

Certificate No.

Code Nos.

HCC/HCH/HDC/HDF/HSQ/HAx/HIQ (heating elements)

Baseefa 02ATEX0046X

 II 2 G EEx e II T6 to T1

HCC/HCH/ HDC/HDF/HSQ/HAx/HIQ (bulk cable)

Baseefa 02ATEX0045U

 II 2 G EEx e II T6 to T1

For other national approvals please contact Pentair Thermal Management.

The order reference of MI heating units uses the following nomenclature

B/HSQ1M1000/43.0M/1217/230/2.0M/SC1H2.5/X/M20/EX

								Area classification: EX, ORD
								Gland size M20, M25, etc...
								Hot/cold joint material type: X -stainless steel, Y - brass, LW - laser welded
								Cold lead size and sheath type (see table on next page)
								Cold lead length: M for unit in meters (standard is 2 m)
								Heating unit: Operating voltage
								Heating unit: total wattage in W
								Unit length: M for unit in meters
								Heating cable reference
								Heating cable unit type: Type B, D or E

When ordering, the complete order reference of the MI heating unit needs to be provided. For hazardous areas, information must also be provided about the T-rating and temperature data relevant to the application (max. sheath temperature data) to enable the correct representation of data on hazardous area tags attached to the completed heating unit in the factory. Before installation, check the suitability of the heating units supplied. Changes to any of the parameters may require a re-design and must be confirmed before installation.

2 HEATING CABLE SELECTION AND STORAGE

The selection of the proper heating cable and components, best suited for the application must be checked against the relevant product literature, the most important product properties are summarized in following table:

Table 1: Properties of MI heating units

MI Heating Cable Type	HCC/ HCH	HDC/ HDF	HSQ
Number of conductors	1	1	1
Maximum voltage (U0/U)	300 / 500 V		
Maximum withstand temp.(1)			
Brazed heating unit	200°C	400°C	450°C
Laser welded heating unit	-	-	700°C
Temperatureclassification	T6 – T3	T6 – T2	T6 – T1
Minimum cable spacing	25 mm		
Minimum installation temp.	-60°C		
Minimum bending radius	6 x Cable Diameter		
Chemical resistance	Low	Medium	Medium

MI Heating Cable Type	HAx1N	HAx2N	HAx2M	HIQ
Number of conductors	1	2	2	1
Maximum voltage (U0/U)	346/600 V		300/300 V	300/500 V
Maximum withstand temp.(1)				
Brazed heating unit	450°C	450°C	450°C	450°C
Laser welded heating unit	650°C	650°C	650°C	700°C
Temperature classification	T6 – T1	T6 – T1	T6 – T1	T6 – T1
Minimum cable spacing	25 mm			
Minimum installation temp.	-60°C			
Minimum bending radius	6 x Cable Diameter			
Chemical resistance	High	High	High	High

⁽¹⁾ The hot-cold junction used in a heating unit may lead to temperature limits below the limit of the heating cable. Contact Pentair Thermal Management if the exposure temperature exceed values given in the tables above for more detailed instructions how the unit can be installed under those circumstances.

Please check against individual datasheet or contact Pentair Thermal Management for further details.

The maximum cable power output is directly dependant on the application and control method used. The actual limits of MI heating cables in a specific application are given in Pentair Thermal Management Engineering Software (e.g. TraceCalc Pro design software). For more details, please contact Pentair Thermal Management.

Ensure that the heating cable voltage and temperature rating is suitable for the application.

Changing design parameters such as voltage or cable length will result in a different power output and maximum sheath temperature. This may require a redesign of the entire system.

To prevent fire or explosion in hazardous areas, verify that the maximum sheath temperature of the heating cable is below T-class or auto-ignition temperature of the gases present in those areas. For further information, see design documentation (e.g. TraceCalc Pro reports).

For the evaluation of the chemical resistance of MI heating cables (for corrosion aspects), refer to our product datasheets or contact Pentair Thermal Management for assistance. Check the design specification to make sure the correct heating cable is installed on each pipe or vessel. Refer to Pentair Thermal Management product literature to select an appropriate heating cable for each thermal, chemical, electrical and mechanical environment.

Storage

- ▶ Store MI heating units in a clean, dry place.
- ▶ Protect the heating cable from moisture and mechanical damage.
- ▶ Storage below 10°C may result in surface condensation, potentially causing low insulation resistance.
- ▶ After extended storage, it is strongly recommended to measure the insulation resistance of MI heating units prior to installation, also refer to section 8.

3 HEATING CABLE INSTALLATION

Warning

As with any electrical equipment or wiring installation that operates at line voltages, damage to heating cable and components, or incorrect installation that allows the penetration of moisture or contamination can lead to electrical tracking, arcing and potential fire hazard. In case of damage and later repair on site any unconnected heating cable end, exposed to the environment, must be sealed appropriately.

3.1 Pre-installation checks

Check design recommendations:

- Verify that you have all required engineering documents supporting the installation
- Check for any special instructions in engineering documentation (e.g. cover with aluminium foil, use of metal mesh, fixation etc...).
- Verify that hazardous area information given in engineering documentation is compatible with the area classification the material will be installed in.

Check materials received:

- Inspect heating cable and components for in-transit damage.
- Review the heating cable design and compare the list of designed materials to the catalogue numbers of heating cables and electrical components received to confirm that proper materials have been received on site. The heating cable type and hazardous area marking (if applicable) is printed on a tag label supplied with each heating element.
- Measure and note down the electrical resistance and the insulation resistance of the cable. Compare these values to those in the design documents (see section 8).

Check equipment to be traced:

- Check identification, length and diameter of pipework/ vessel against the design documents. Also verify, that actual temperatures and insulation properties are in alignment with the design documentation.
- Ensure all pressure testing of pipework/ vessel is complete and final paint and pipe coatings are dry to touch.
- Walk the system and plan the routing of the heating cable on the pipe, including tracing of heat sinks. e.g. valves, flanges, supports, drains etc.

- Inspect piping for burrs, rough surfaces, sharp edges etc. which could damage the heating cable. Smooth off or cover with layers of aluminium foil. At elevated sheath temperatures consider the use of stainless steel foil. (e.g. HSQ; HIQ or HAx).
- Surface areas where heat-tracing is to be installed must be reasonably clean. Remove dirt, rust and scale with a wire brush and oil and grease films with a suitable solvent.

3.2 Heating cable pulling and laying

Heating cable pulling tips:

Figure 3: Importance of cable pulling direction

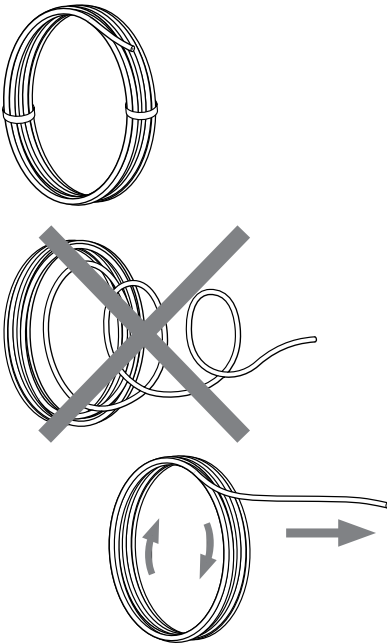

- Avoid distortion of the cable and kinking.
- When pulling the heating cable, avoid:
 - ◻ sharp edges
 - ◻ excessive pulling force
 - ◻ kinking and crushing
 - ◻ running over it with equipment.

The minimum bending radius of the heating cable must be respected.

Figure 4 : Minimum bending radius of MI heating cables

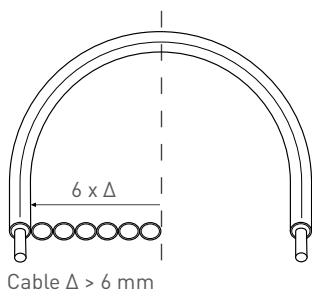

- Do not repeatedly bend and straighten the cable.
- Keep heating cable strung loosely but close to the pipe being traced, to avoid interference with supports and other equipment.
- **Add additional heating cable to trace the fittings and supports as required by the design specification or engineering documents.**
- Leave the appropriate amount of heating cable at all power connection, splice and tee locations.
- Do not bend the cable within 150 mm of the hot to cold junction or remote terminations.
- When installing MI and other constant wattage heating cables, ensure that they do not overlap or cross. Doing so may lead to local over-heating and hazard of fire.

Figure 5 : Minimal spacing must be respected

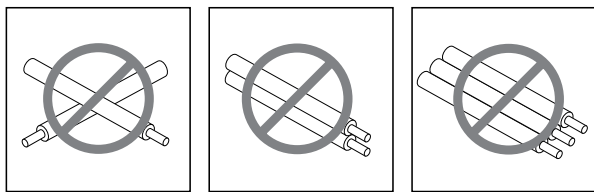

Minimum cable spacing: 25 mm (lower spacings may be possible but require special attention and must be properly documented in the engineering documentation).

For installation in hazardous areas, the standard minimum spacing is 50 mm. This must be respected, unless lower spacings are specifically allowed in the engineering documentation.

Table 2: Typical allowances (in mm) per run of cable

NPS inch	DN mm	Light valve (flanged)	Light valve (threaded or welded)	Heavy valve (flanged)	Heavy valve (threaded or welded)	Typical pipe shoe	Flange pair	Field variance
0.5	15	300	300	300	300	910	300	2%
0.75	20	460	300	460	300	910	300	2%
1	25	610	300	610	300	910	460	2%
1.5	40	760	460	910	460	910	460	2%
2	50	760	610	1060	610	910	460	2%
3	80	910	760	1220	760	910	610	3%
4	100	1220	910	1520	910	910	610	3%
6	150	1520	1060	1830	1060	910	610	3%
8	200	2140	1220	2440	1220	910	610	3%
10	250	2440	1520	3050	1520	910	910	3%
12	300	2750	1830	3660	1830	910	1060	3%
14	350	3050	2140	4270	2140	1370	1220	3%
16	400	3350	2440	4880	2440	1370	1370	3%
18	450	3660	2750	5500	2750	1370	1680	3%
20	500	3970	3050	6100	3050	1370	1830	3%
24	600	4580	3660	7320	3660	1370	2140	3%

1. Allowances above are based on typically available fittings and supports, with an insulation thickness equivalent to the pipe insulation. Please refer to the engineering documentation for project specific allowances.
2. For pipes requiring more than one run of heating cable, apply the full allowance for each run of cable on each fitting or support as long as space allows. However, MI heating cables must not touch or overlap and the minimum spacing between the heating cables must be respected.
3. For some applications, it may be physically impossible to install all of the recommended heating cable directly on the fitting or support. In this case, install the excess heating cable on the pipe, on either side of the fitting or support, or distribute the additional heater length along the entire circuit length if a lower local temperature is acceptable. This constraint may be difficult for small pipes and/or multiple cable runs. If required, contact Pentair Thermal Management for assistance.
4. The field variance is important to accommodate expansion and contraction of the heated equipment. Also refer to figures 12-14 for more detailed information.

3.3 Heating cable attachment

- Fix in place with metal bandings, tie wire or wire cloth band at a typical interval of 300 mm and additionally where necessary.
- The use of tie wire with softer sheath MI heating cables (like copper HC and cupro-nickel HD) should be avoided, as the tie wire can damage the heating cable surface over time. Do not tighten tie wire, use wire cloth band wherever possible.
- The hot to cold junction should be secured with metal bands at a typical distance of 150 mm on either side of the joints.
- Cable must be installed and fixed such that movement of cable during its heating up cycles is permitted, but not to allow cable to move freely under its own weight. Other attachments (like aluminium tape or glass tape) may be used, if specified in the design documentation.
- The heating cables may be installed in straight, multiple runs as required by the design specification.
- On horizontal pipes fix on lower quadrant as shown below and not on bottom of pipe.

Figure 6 : Cable orientation on pipe

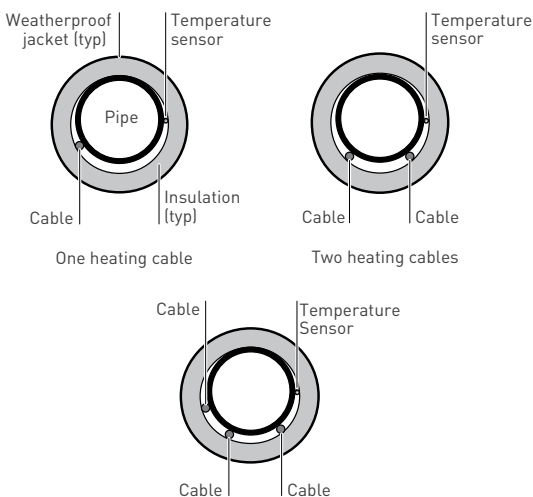

- On vertical pipe sections fix the heating cables equally distributed around the pipe circumference.
- Read the design documents, in particular concerning the need for cable allowances and regard the location of junction boxes/ controllers before permanently attaching the cable to the pipe.

- Verify if the design documentation requires that the heating cables have to be covered by aluminium or stainless steel foil before the insulation is applied.
- Installation on tanks typically requires additional fixing devices as pre-punched steel strips as shown below:

Figure 7: Typical cable layout on large surfaces like tank walls

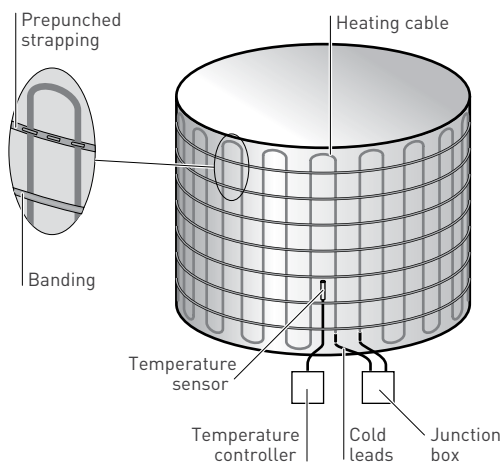
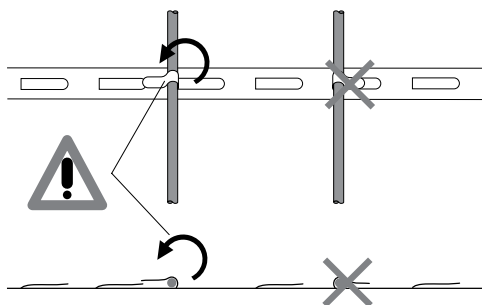

Figure 8: Fixing device: pre-punched metal strap



- Avoid sharp edges and properly seal penetration of MI cold lead cables through the insulation cladding.

3.4 Attachment materials

- Stainless steel pipe straps for different pipe dimensions up to 36 " (e.g. PB 300).
- Stainless steel banding (30 m roll) together with stainless steel buckles (one per fixing) (e.g. SNLS + SNLK).
- Tie wire (e.g. RMI-TW) is especially suitable for the fixation on irregular shapes like pumps, valves etc.. The use of tie wire with softer sheath MI heating cables (like copper HC and cupro-nickel HD) should be avoided where possible, as the tie wire can damage the heating cable surface over time, use wire cloth band wherever possible. For the installation of MI heating cables on metal meshes, tie wire may be used, but must not be tighten and should allow for free movement of MI heating cable during expansion and contraction.
- Pre-punched metal banding allowing fixed heater spacing, where multiple runs of cable are applied (e.g. HARD-SPACER-SS-25MM-25M).
- Various types of metal meshes are available for installation on tanks, valves, pumps (e.g. mesh types FT-19 and FT-20)

3.5 Typical installation details

The following details show some principles of MI cable installation, using dual conductor cables. Single conductor cables follow the same principles, but typically form a loop. Attention must be given, for single conductor configurations, where both ends need to be terminated in the same power supply box.

- **Where feasible, uncoil the heating cable and lay it alongside the pipe section to be traced.** For shorter single conductor cable, to be installed in the form of a „hairpin“, it may be advantageous to unroll the heating cable, loop it, and then lay it alongside the pipe section so that both runs of cable can be installed simultaneously.

Figure 9: Uncoiling heating cable

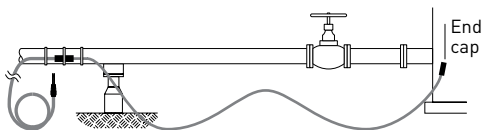
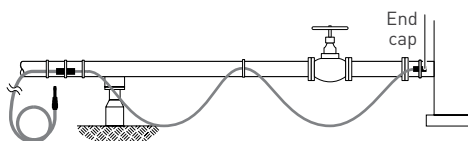
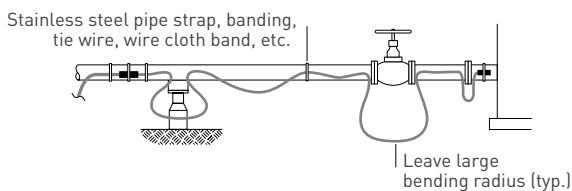

Figure 10: Attaching hot-cold joint and end cap



- Attach hot-cold joint to end of pipe nearest the power supply point, and the other end of heating cable to the other end of the pipe. Support hot-cold joint by attaching cable with pipe straps/banding at a distance of 6 inches (150 mm) on either side of joint. Secure joint itself to pipe with a pipe strap/band as shown in Figure 10.
- Fasten middle of heating cable to the halfway point of pipe leaving equal slack on either side.
- Attach heating cables to pipe with pipe straps/banding, tie wire or wire cloth band at 12-18 inches (300-450 mm) intervals. Tie wire should be snug, but should not cut or indent the sheath.
The use of tie wire with softer sheath MI heating cables (like copper HC and cupro-nickel HD) should be avoided, as the tie wire can damage the heating cable surface over time, use wire cloth band wherever possible.

Figure 11: Allowances for valves, flanges, and pipe supports



- Use tie wire or wire cloth band to hold cable to irregularly shaped objects such as valves or pipe supports.

Figure 12: Installing cable on valves and pipe supports

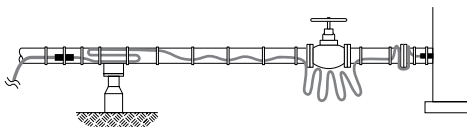

- Allow cable to wave along pipe as per Figure 14 und 15. This allows for expansion and contraction of the heating cable as it heats up and cools down. Use up excess cable by waving along pipe and increasing amount used at each pipe support.
- **Note: Do not use up excess cable at one location. Distribute equally along pipe.**

Figure 13: Completed MI heating cable installation

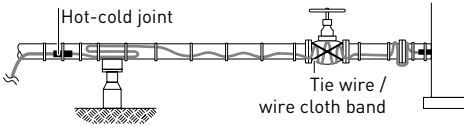

Figure 14: Pipe strap spacing

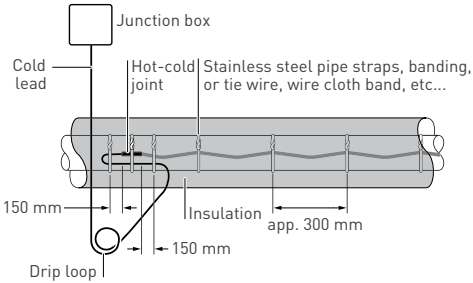
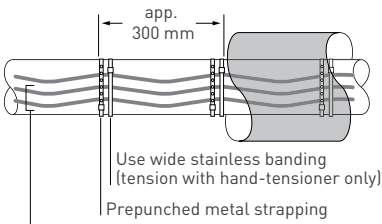

Figure 15: Fastening several runs of cable



Wave cables with a minimum spacing of 25 mm to 50 mm along pipe, unless design documentation clearly states other values.

► **Note:** Where several heating cables are required, a pre-punched metal strapping may aid the installation and consistent spacing of heating cables.

Figure 16a: Valves

For valve sizes $3\frac{1}{2}$ " (90 mm) or smaller

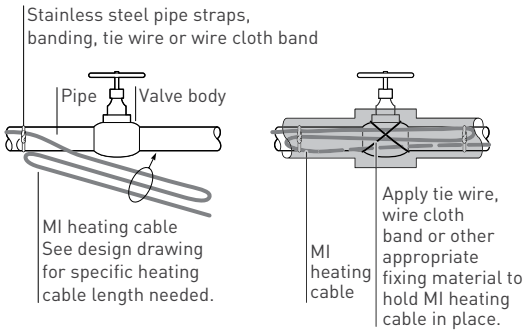
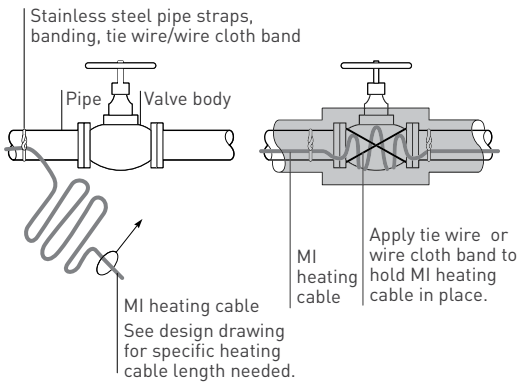

Figure 16b: Valves

For valve sizes larger than $3\frac{1}{2}$ " (90 mm)



- The minimum spacing must be respected, unless design documentation clearly states other values, also refer to page 11, figure 5.

Figure 17: Installation at 90° elbow

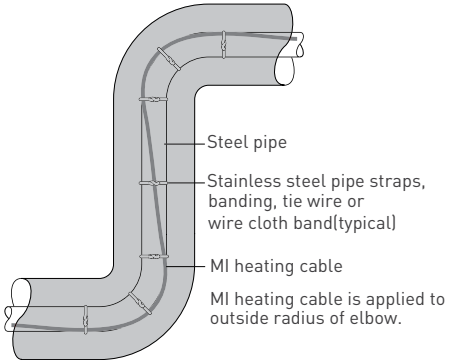

Figure 18: Flanges

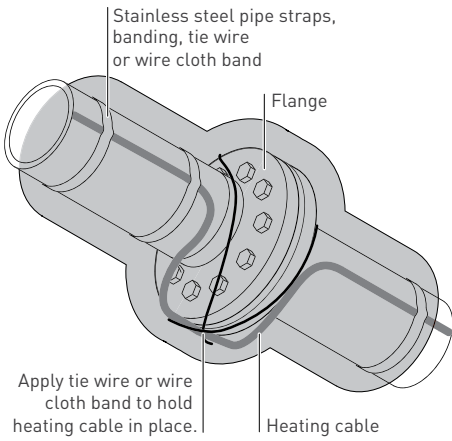

Figure 19: Cable layout over clamps and straps

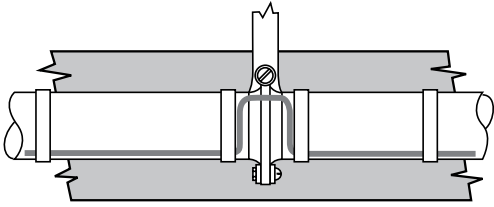
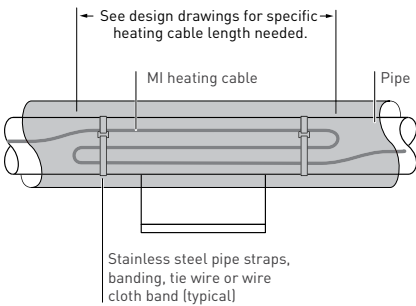
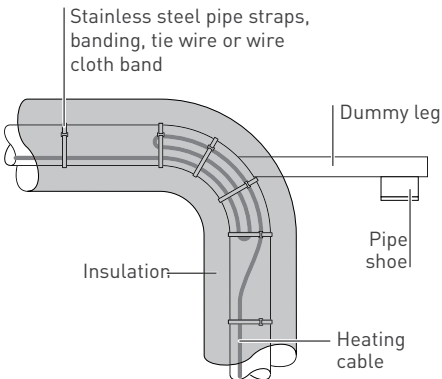

Figure 20 : Shoe and sleeve type support



► The minimum spacing must be respected, unless design documentation clearly states other values, also refer to page 11, figure 5.

Figure 21: Dummy supports



- The minimum spacing must be respected, unless design documentation clearly states other values, also refer to page 11, figure 5.
- Check drawings for dummy leg insulation.
- Pumps should have their own heating cable, separate from the connection box.

Figure 22: Pumps

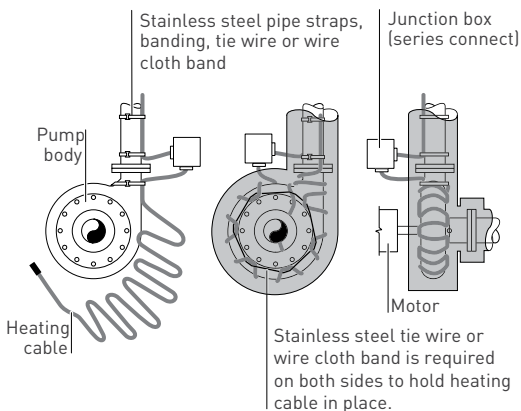

- The minimum spacing must be respected, unless design documentation clearly states other values, also refer to page 11, figure 5.
- Cover the heating cable with metal foil or equivalent before applying insulation to ensure the cables do not become trapped in the insulation.
- **General note:**
Trace pipe fittings as shown to allow easy maintenance. An alternative is the use of metal wire mesh cages.

Figure 23 : Cable applied on metal wire mesh

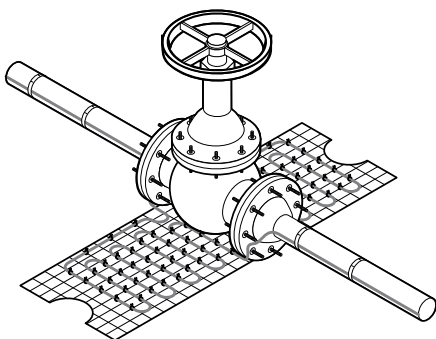

- ▶ Consult the design specification for the heat-tracing requirements of fittings and supports.
- ▶ The heating cable's minimum bend radius must be respected (refer to Table 1).
- ▶ The minimum spacing must be respected, unless design documentation clearly states other values, also refer to page 11, figure 5.

3.6 Heating cable allowances

All parts of a heat traced system that increase the surface area of the insulated pipe/ vessel or metallic fins that protrude out of the insulation (e.g. supports), will increase the overall heat loss. These areas of increased heat loss require compensation, either by using higher overall design safety factors or by the addition of extra cable length. In such cases sufficient cable should be added to at least enable removal of instruments, valves etc ("maintenance loop").

For further details on individual allowances please refer to Pentair Thermal Management design specification (e.g. TraceCalc Pro reports).

4 COMPONENTS SELECTION AND INSTALLATION

4.1 General notes

Use the Design Specification to select required components. Pentair Thermal Management components must be used to satisfy Standards and Approval Body requirements and the Pentair Thermal Management warranty to apply.

4.2 Component installation hints

- On horizontal pipes locate junction boxes below pipe where ever possible.
- Locate junction boxes for easy access, but not exposed to mechanical abuse.
- Try to position junction boxes such, that power cable and heating cable entries point downwards to avoid water ingress in the insulation.
- Confirm junction box glands and stopping plugs are appropriate for application and fixed firmly in place.
- Route heating cable between junction box and the place where it enters the insulation cladding such, that the risk of mechanical damage is minimized.
- Do not strain heating cable as it exits/enters junction boxes and insulation entries.
- Ensure heating cable is fixed over pipe straps such as used for junction box support brackets so as to avoid potential mechanical damage:
- Cable joints (splices) should be located only in places, where cable is not bent or mechanically stressed.

5 TEMPERATURE CONTROL AND LIMITATION

5.1 General rules

Pentair Thermal Management MI series heating cables are constant power output heaters and as such typically require temperature control, unless otherwise explicitly specified.

Good practice and local regulations may require additionally independent temperature limitation devices; The selection of such devices also depends on environmental conditions (non-haz or haz area).

- For applications in hazardous areas either a stabilized design or a thermostat control with temperature limiter complying with the requirements of IEC 62086 and EN 50019:2000 can be used to limit the surface temperature of the heating cable.
- In cases where stabilized design is not applicable, a control thermostat must ensure that the heating system under normal conditions will be switched off, as soon as maintain temperature is reached.
- An additional, independent temperature limiter ensures that the surface temperature of the heating cable will not exceed the maximum allowed temperature of hazardous area if the control thermostat fails.
- A lockout function ensures that the heating cable remains switched off, until failure has been eliminated and normal conditions are restored.
- The lockout function is manually re-armed. Reset requires a tool (e.g. a key to open a panel or a password for software).
- Value of setpoint has to be secured against unintended change.
- Limiter must permanently switch off in case of sensor malfunction.
- The limiter function is tested against relevant standards (e.g. EN60730 or DIN3440 etc.).

- Follow the installation instructions supplied with the thermostat and/or the limiter.
- Use a proper wiring diagram for the heating cable layout and control method desired.
- The limiter must be set to ensure that the maximum temperature of the surface of the cable does not exceed either T-class or maximum working temperature of the heater for a given output under worse case conditions.
- **Warning**
As with any temperature measurement equipment, possible falsification of true temperatures due to increased heat loss caused by the sensor itself might lead to inaccurate temperature readings or unsafe tripping of safety limiters. The setpoint might need to be adjusted accordingly. Contact Pentair Thermal Management or the supplier of the limitation device in order to obtain detailed information concerning offsetting of limitation devices.

5.2 Sensor placement: Temperature control device

The choice of the right location for the controller sensor depends on, but is not limited to following aspects:

- Flow direction of the fluid, best location: downstream.
- Impact of heat sinks such as supports etc, best location: close to heat sink.
- Chimney effect on large size vertical pipes, best location: on the bottom.
- Accessibility for maintenance purposes, best location: at ground level.
- Impact of other heat sources, sun etc., best location: at cold side.

For details please refer to the engineering documentation.

5.3 Sensor placement: Temperature limiter device

Typically the sensor is being placed on a length of cable, that is separated from the pipe by means of insulating material, in order to create an “artificial hotspot”. The choice of the right location for the limiter sensor depends on, but is not limited to following aspects:

- Flow direction of the fluid, best location: upstream in case of warmer inrushing fluid.
- Impact of heat sinks such as supports etc, best location: away from heat sinks.
- Accessibility for maintenance purposes, best location: at ground level.
- Chimney effect on large size vertical pipes, best location: at the top.
- Impact of other heat sources, sun etc., best location: at hot side of pipe.
- It is the responsibility of the installer to ensure that these conditions are met in the most appropriate way.
- For more details please refer to the engineering documentation.

6 THERMAL INSULATION AND MARKING

6.1 Pre-insulation checks

- Visually inspect the heating cable and components for correct installation and possible damage. (See Section 10 if damaged.)
- Insulation resistance testing (as per Section 8) is strongly recommended prior to covering the pipe with thermal insulation.
- Discharge cable immediately after insulation test.

6.2 Insulation related requirements

- Correct temperature maintenance requires properly installed and dry thermal insulation.
- The sheath temperature of an MI heating cable can be substantially above the temperature of the pipe/equipment to be traced. Verify that the max. sheath temperature of the heating cable is compatible with the insulations materials to be used. Contact your Pentair Thermal Management representative if you have any questions.
- Check that all pipes, including fittings, wall penetrations and other areas are completely insulated.
- Thermally insulate and weatherproof to design specification.
- Ensure that heating cable is not damaged during installation of cladding by drills, self tapping screws and sharp edges of cladding etc.
- In all stabilized design cases, the characteristics of the installed thermal insulation (material and thickness) must comply with the design requirements and be verified and confirmed in the documentation, to ensure compliance with approvals requirements.
- Make sure, that under no circumstances any insulation material is being placed between heated surface and cable, thus disabling intended heat flow to the substrate, which may result in possible overheating of the cable.

- Good practice requires wrapping of the installed heating system with an appropriate metal foil prior to installation of the thermal insulation. This is especially so at places where intimate contact between heat-tracing cable and heated surface is not possible, such as valves or flanges where a suitable heat sink of temperature rated metal foil and wire cloth band may be used to improve heat-transfer. Also refer to design documentation, which may specify this requirement as well as material type, thickness etc... Further details may also be described in local insulation standards.
- Check that all HC or HD cables are mechanically protected and properly sealed at all places where they penetrate the insulation cladding.
- Ensure that all places are sealed where thermostat capillaries, sensor cables or support brackets etc. exit the cladding.

6.3 Marking

- Install "Electric Traced" signs on the insulation cladding along piping at suitable intervals (3-5 m intervals recommended) on alternate sides as a warning.
- Mark on outside of insulation the location of any heating cable components like connection points, splices etc.

MI-Heating unit identification:

- Each MI heating unit is supplied with an identification tag with important details about the type and operation conditions of the unit.
- In hazardous areas, the cable tag is mandatory.
- The tag contains the area classification in addition to other relevant design information.

**Figure 24: Typical MI identification tag
(for use in hazardous areas)**

		CE 1180	
MI Unit Reference: B/HSQ1M1000/43M/1187/230/2M/SC1H2.5/X/M20/EX			
Heating Cable Ref.:	HSQ1M1000	Element Length:	43 m
Year of Manufacture:	2006	Circuit Length (if different):	
Grade:	II (high)	Design Temperature Class:	T1 Zone1
Design Method:	Limiters-Lockout	Maximum Withstand Temperature:	450°C
Max. Sheath Temperature:	331°C	Sheath Reference Temperature:	200°C
Nom. Power Output @ 230 V:	1187 W @ Maintain Temperature		
Order No:		Customer Order No:	
Batch number:	XXXXXX	Circuit Reference:	
Type Examination No:	Baseefa02ATEX0046X		
 II 2 G EEx e II T1			
Follow installation and operating instructions for safe use in hazardous areas!			
THIS TAG MUST NOT BE REMOVED			

- **MI Unit Reference** is the order reference following the nomenclature of MI heating units (also see page 6)
- **Heating Cable Ref.** is the type of MI heating cable
- **Element length** is the heated length of the MI unit
- **Year of Manufacture** is the manufacturing year
- **Circuit length (if different)** informs about the “total circuit length” in case of multiple elements being connected in series
- **Design Temperature Class** states the “T-class” or “Auto Ignition Temperature” including the “Zone” classification, which the unit is designed for
- **Design method** informs about the method of temperature control, which has been used for the design and must be installed to control the heating unit.

Examples:

- 1) “Stabilized” indicates that the design method used is “stabilised design”. All parameters used in the design of the application must be respected in order to comply with the hazardous area requirements (e.g. pipe diameters, insulation thickness, process, ambient conditions ...). The reference temperature for the sheath temperature calculations is either the calculated “max. uncontrolled temperature” or the “max. process temperature”, whichever is higher.
- 2) “Control limited” indicates that the design method used is “control limited design”. The reference temperature for the sheath temperature calculations is the control limited set point and must be assured by the use of an alarm capable control unit making sure the heating element is switched off, when the pipe/equipment exceed this temperature. The use of a wrong control device or a change of the temperature setting will invalidate the design calculation.
- 3) “Limiters-Lockout” indicates that the design method used assumes the installation of an approved limiter (typically a safety temperature limiter which sensor is installed on the heating cable surface using an “artificial hotspot”). The set point of the limiter must be below the T-class of the area and may require an additional down-adjustment for potential falsifying of the measured temperature, refer to the instructions given by the manufacturer of the limiter.

- **Maximum Withstand Temperature** is the max. withstand temperature of the heating cable and the hot-cold joint used, it may also be limited by the hazardous area approval
- **Max. Sheath Temperature** is the max. sheath temperature of the MI heating cable based on the application design data
- **Sheath Reference Temperature** is the reference temperature, which the "max. sheath temperature" calculated in the design of the system is based upon, (also see "Design Method")
- **Power Output** refers to the expected power of the heating unit at the specified voltage/configuration. It is based on the desired maintain temperature and may be significantly lower than during start-up phase, in particular for heating cables using conductors with a high temperature coefficient (e.g. copper conductor). Refer to the design information for proper sizing of the circuit breaker and power supply.

The design calculation must always be in compliance with the application design and the ambient parameters.

Figure 25: Typical MI identification tag (non-hazardous areas)

		CE
MI Unit Reference: B/HSQ1M2500/11.5M/1840/230/0.5M/SC1H2.5/LW/M20/ORD		
Heating Cable Ref.:	HSQ1M2500	Element Length: 11.5 m
Year of Manufacture:	2006	Circuit Length (if different):
Grade:	II (high)	
Nom. Power Output at 230 V: 1840 W @ Maintain Temperature		
Order No:	451286	Customer Order No:
Batch number:	XXXXXX	Circuit Reference:
Follow installation and operating instructions.		
THIS TAG MUST NOT BE REMOVED		

7 POWER SUPPLY AND ELECTRICAL PROTECTION

- ▶ Do not energize cable when it is coiled or on the reel.

7.1 Earth connection

- ▶ Bond the metal sheath of the heating cable to a suitable earth terminal.

7.2 Electrical loading

Size overcurrent protective devices according to the design specification and/or local standard practices.

7.3 Residual current (earth fault) protection

Pentair Thermal Management requires the use of a 30mA residual current device to provide maximum safety and protection. When design results in a higher leakage current, a maximum 300mA RCD may be used. All safety aspects need to be proven. Also refer to local standards. Special regard should be given to electrical safety in IT power networks where use of RCD is restricted. For any heating cables installed in a hazardous area, the use of residual current devices is mandatory by the electrical codes and standards.

7.4 Isolation from power supply

For any heating cables installed in hazardous areas a means of isolation all line conductors from the supply is recommended.

7.5 Circuit marking

Make sure for all hazardous area installations, that system is properly marked with a heating cable tag.

8 SYSTEM TESTING

WARNING: Fire hazard in hazardous locations. Megger tests can produce sparks. Be sure there are no flammable vapors in the area before performing this test (hot work permit).

8.1 Testing of insulation resistance and conductor resistance

Pentair Thermal Management recommends insulation resistance test

- ▶ before installing heating cable, while the cable is still on the reel
- ▶ before installing thermal insulation
- ▶ prior to initial start-up/ after completion of thermal insulation
- ▶ as part of the periodic maintenance (see Section 9.2).

The heating circuit electrical resistance needs to be measured and compared to the design documentation before initial startup.

8.2 Test method for insulation resistance testing

After completing heating cable installation, the insulation resistance between the conductor and the outer sheath has to be tested (see Section 6.1).

All mineral insulated heating cables:

Use a minimum testing voltage of 500V and not more than 1000 V DC (between conductor and metal sheath).

For hazardous areas a testing voltage of 1000V DC is recommended.

Minimum readings should be $\geq 20 \text{ M}\Omega$ for new heating units. The installer should record the values for each circuit on the installation record sheet.

9 OPERATION, MAINTENANCE AND REPAIRS

WARNING: Heating cables are capable of reaching high temperatures during operation and can cause burns when touched. Avoid contact when cables are powered. Thermally insulate the traced pipe or equipment before energizing the cable. Use only properly trained personnel.

9.1 Heating cable operation

- Temperature exposure to the cable must be within the range specified in the product literature. Exceeding the limitations will shorten the service life and may permanently damage the heating cable and/or connections.
- Pipe insulation must be complete and dry to maintain the required temperature.

9.2 Inspection and maintenance

- Visual inspection: heating cable exposed to ambient and pipe insulation should be checked periodically to make sure, that no mechanical damage has occurred.
- Insulation testing: The system should be tested regularly. Check in advance, whether hazardous area conditions allow insulation testing. A hot work permit might be required.
- When measuring the insulation resistance from the main supply panel, the dielectric test is performed between L (live) and PE (earth).
- Functionality test of electrical protection: Circuit breaker and residual current device should be tested at least once a year or according to manufacturer's instructions.
- Functionality test of temperature control systems: Depending on how essential temperature control is regarding process requirements and how critical temperature limitation is for accordance with hazardous area requirements, test should be carried out at regular intervals.
- The Installation Record Sheet on the following pages should be completed during maintenance of each circuit in your system. Freeze protection systems should be measured before the winter months each year (see section 8).
- Temperature maintenance systems should be tested at least twice a year.

9.3 Piping systems repair and maintenance

- ▶ Isolate heating cable circuit and protect the heating cable from mechanical or thermal damage during pipe repair work.
- ▶ Check heating cable installation after pipe repairs and make sure, that thermal insulation is restored, following the recommendations in Section 8. Check correct functioning of all relevant electrical protection systems.

10 TROUBLE SHOOTING

WARNING: Damage to cables or components can cause sustained electrical arcing or fire. Do not energize heating cables that have been damaged. Damaged heating cable or terminations must only be repaired or replaced by qualified personal. Contact Pentair Thermal Management for assistance.

- ▶ It should be carefully evaluated, whether the severity of the damage allows on-site repair or whether the entire heating cable needs to be replaced.

Also refer to the Troubleshooting guide on the following pages. If the problem persists after following the guidelines, contact Pentair Thermal Management.

INSTALLATION RECORD SHEET

Heating Cable Installation Record

Installation company :	Installer:	
Project / Site name:		
Area name:		

Value/Remarks	Date	Initials
Heating circuit number:		
P & ID -number:		
Drawing number:		
Panel/Circuit breaker number:		
Heating cable type:		
Cable length (m):	loop 2 x: m, star 3 x: m	

	Required value	Actual value	Signature
1 Visual inspection			
Minimal allowed spacing	mm		
Minimal bending radius	mm		
Temperature sensor properly installed on the pipe and control temperature is set	yes		
Sensor of temperature limiter properly installed and set according to design specification	yes		
2 Before commencing of thermal insulation works			
Insulation resistance test voltage (V DC)	1000 V DC		
Insulation resistance test before thermal insulation (MΩ)	> 20 MΩ		
Loop resistance	ohms		
Average pipe temperature when measuring loop resistance:	°C		
Cable covered with metal foil at flanges, valves, metal wire mesh cages etc., as per requirements in design documentation	yes		

3 After finalization of thermal insulation works

Cables are sealed and protected at entries into insulation cladding	yes		
Thermal insulation material and thickness meet designed values	yes		
Warning labels installed on cladding every 5 m and at components	yes		
Insulation resistance test voltage V DC	1000 V DC		
Insulation resistance test after insulation	MΩ		

4 Prior to energizing of the cable

Circuit feeding box marked properly	yes		
Control temperature set to setpoint	°C		
Limiter set to trip value and protected against changes	°C		
Insulation resistance test voltage V DC	1000 V DC		
Insulation resistance test at commissioning	MΩ		
Circuit voltage at feeding box Ph-Ph, Ph-N for 3 phase	V		

SYMPTOM AND PROBABLE CAUSES

A **Symptom:** Insulation resistance less than expected

Probable Causes

- 1 Rainy or high humidity
 - 2 Nicks or cuts in heating cable sheath, with moisture present
 - 3 Kinked or crushed heating cable.
 - 4 Arcing created by damage to the heating cable.
-

- 5 Physical damage to heating cable is causing a direct short.
-

- 6 Presence of moisture in terminations or connections
-

- 7 Damaged termination
-

- 8 Moisture in junction boxes
-

B **Symptom:** Circuit breaker trips

Probable Causes

- 1 Circuit breaker undersized
 - 2 Defective circuit breaker
 - 3 Short circuit in electrical connections
 - 4 Excessive moisture in connection boxes
 - 5 Nicks or cuts in heating cable sheath, moisture present
 - 6 Kinked or crushed heating cable
 - 7 Defective RCD
 - 8 Excessive earth leakage current, RCD trips
-

Corrective actions

- 1 Dry tails and face of seal

- 2, 3, 4 Visually inspect cable for damage, especially at elbows, flanges, and around valves. If damaged, repair or replace heating cable.
Inspect power connection box for moisture or signs or tracking.
Dry out connections and retest.

- 5 Check for visual indications of damage around the valves, pump, and any area where there may have been maintenance work. Look for crushed or damaged insulation along the pipe. Replace damaged sections of heating cable.

- 6 Dry out cold lead and/or connections and replace termination if necessary.

- 7 Replace termination

- 8 Check and replace seals on junction boxes

Corrective actions

- 1 Recalculate circuit load current. Resize breaker as required

- 2 Repair or replace breaker

- 3 Eliminate short circuit. Thoroughly dry connections

- 4 Eliminate short circuit. Thoroughly dry connections

- 5 Repair damaged section or replace heating cable

- 6 Repair damaged section or replace heating cable

- 7 Replace RCD

- 8 Check insulation resistance. If within acceptable range, evaluate electrical design for compatibility with RCD used.

C **Symptom:** Power output appears correct but pipe temperature

Probable Causes

- 1 Wet or missing insulation with proper weather-proofing

- 2 Insufficient heating cable on valves, maintain temperature at flanges, supports, pumps, and other heat sinks

- 3 Temperature controller set incorrectly

- 4 Improper thermal design used

- 5 Temperature sensor in wrong location

- 6 Low fluid temperature entering pipe

D **Symptom:** Power output is zero or incorrect

Probable Causes

- 1 No input voltage

- 2 Temperature controller wired in the normally open (N.O.) position

- 3 Limiter has tripped

- 4 Broken or damaged heating element, hot-cold joint, end cap, or broken tail

- 5 Wrong cable used

- 6 Improper voltage used

Locate faults by the following steps:

- 1 Visually inspect the power connections, splices and
- 2 Look for signs of damage at:
 - end seals for correct installation
 - a) Valves, pumps, flanges and supports
 - b) Areas where repairs or maintenance work has been carried out recently

is below design

Corrective actions

- 1 Remove wet insulation and replace with dry insulation and secure it
 - 2 Confirm compliance with system design. (If valve, flange, and pipe support types and quantities have changed, additional heating cable may be required.)
 - 3 Reset temperature controller
 - 4 Contact your Pentair Thermal Management representative to confirm the design and modify as recommended
 - 5 Confirm that sensor is in the correct location
 - 6 Verify temperature of fluid entering pipe
-

Corrective actions

- 1 Repair electrical supply lines and equipment
 - 2 Confirm wiring using the normally closed (N.C.) terminals so that contacts close with falling temperature
 - 3 Check the reason for the limiter trip. Resolve problem and reset limiter.
 - 4 Repair or replace heating cable
 - 5 Verify installation as per design and replace cable if necessary
 - 6 Verify voltage and connect to proper voltage if necessary
-

- 3 Look for crushed or damaged insulation and cladding along the pipe
- 4 If after 1, 2 and 3 above the fault has not been located, then consult Pentair Thermal Management for further assistance

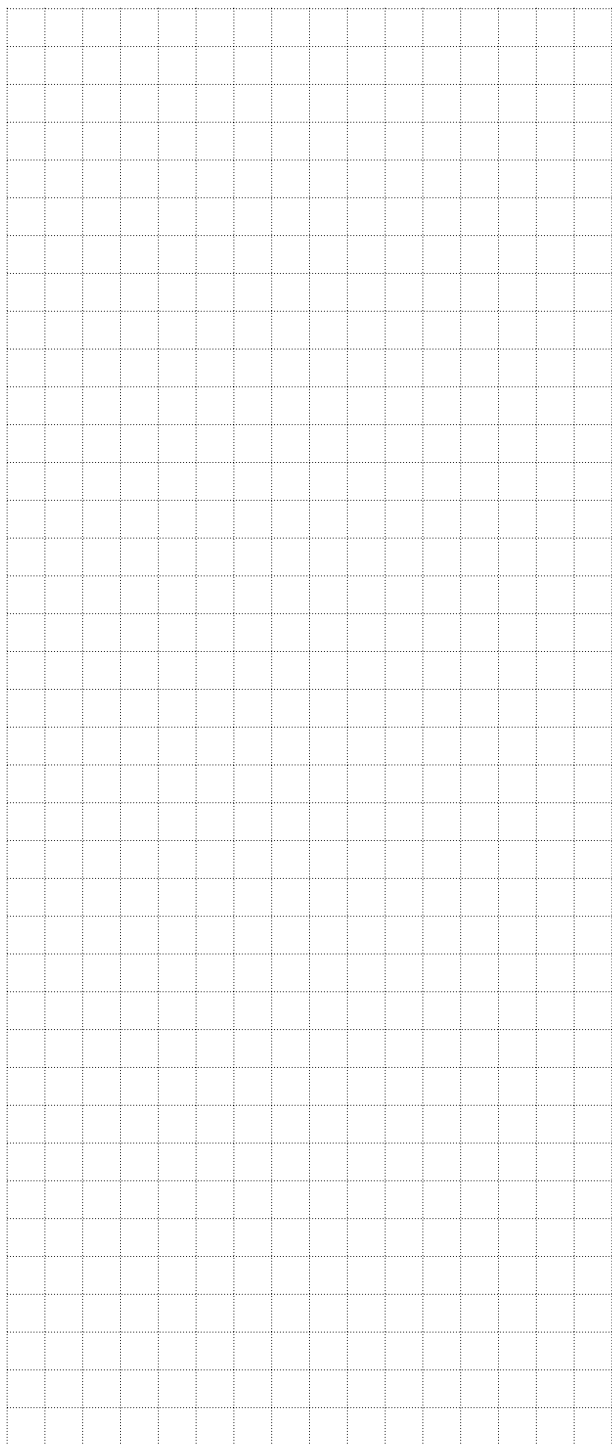

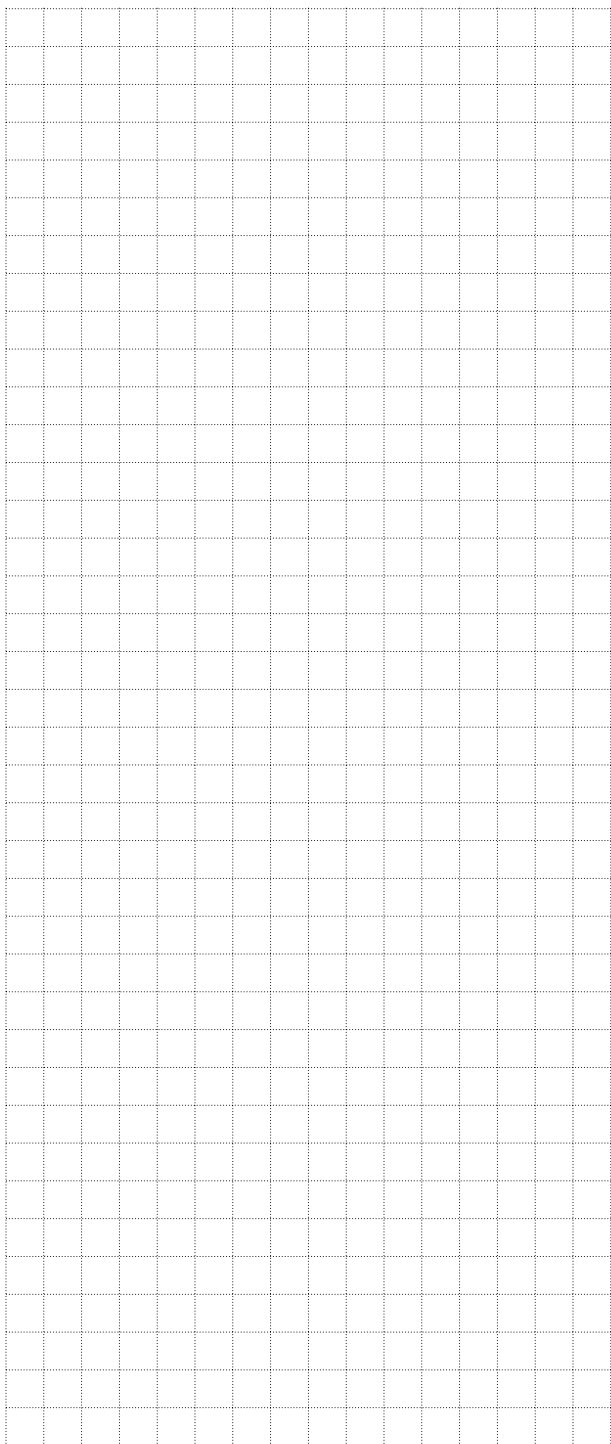

BELGIË / BELGIQUE

Tel. +32 16 21 35 02
Fax +32 16 21 36 04
salesbelux@pentair.com

BULGARIA

Tel./fax +359 56 86 68 86
fax +359 56 86 68 86
salesee@pentair.com

ČESKÁ REPUBLIKA

Tel. +420 241 009 215
Fax +420 241 009 219
czechinfo@pentair.com

DANMARK

Tel. +45 70 11 04 00
Fax +45 70 11 04 01
salesdk@pentair.com

DEUTSCHLAND

Tel. 0800 1818205
Fax 0800 1818204
salesde@pentair.com

ESPAÑA

Tel. +34 902 125 307
Fax +34 91 640 29 90
ptm-sales-es@pentair.com

FRANCE

Tél. 0800 906045
Fax 0800 906003
salesfr@pentair.com

HRVATSKA

Tel. +385 1 605 01 88
Fax +385 1 605 01 88
salesee@pentair.com

ITALIA

Tel. +39 02 577 61 51
Fax +39 02 577 61 55 28
salesit@pentair.com

LIETUVA/LATVIJA/EESTI

Tel. +370 5 2136633
Fax +370 5 2330084
info.baltic@pentair.com

MAGYARORSZÁG

Tel. +36 1 253 7617
Fax +36 1 253 7618
saleshu@pentair.com

NEDERLAND

Tel. 0800 0224978
Fax 0800 0224993
salesnl@pentair.com

NORGE

Tel. +47 66 81 79 90
Fax +47 66 80 83 92
salesno@pentair.com

ÖSTERREICH

Tel. 0800 297410
Fax 0800 297409
info-ptm-at@pentair.com

POLSKA

Tel. +48 22 331 29 50
Fax +48 22 331 29 51
salespl@pentair.com

REPUBLIC OF KAZAKHSTAN

Tel. +7 495 926 18 85
Fax +7 495 926 18 86
saleskz@pentair.com

РОССИЯ

Тел. +7 495 926 18 85
Факс +7 495 926 18 86
salesru@pentair.com

SERBIA AND MONTENEGRO

Tel. +381 230 401 770
Fax +381 230 401 770
salesee@pentair.com

SCHWEIZ / SUISSE

Tel. 0800 551308
Fax 0800 551309
info-ptm-ch@pentair.com

SUOMI

Puh. 0800 11 67 99
Telekopio 0800 11 86 74
salesfi@pentair.com

SVERIGE

Tel. +46 31 335 58 00
Fax +46 31 335 58 99
salesse@pentair.com

TÜRKIYE

Tel. +90 530 977 64 67
Fax +32 16 21 36 04
ptm-sales-tr@pentair.com

UNITED KINGDOM

Tel. 0800 969013
Fax 0800 968624
salothermaluk@pentair.com



WWW.PENTAIRTHERMAL.COM

Pentair is owned by Pentair or its global affiliates. All other trademarks are the property of their respective owners. Pentair reserves the right to change specifications without prior notice.

© 2007-2014 Pentair.