

MSAT (Mid-Span Access Tool)

OPERATING INSTRUCTIONS

Warning! This tool should not be used on live electrical circuits. It is not protected against electrical shock! Always use OSHA/ANSI or other industry approved eye protection when using tools. This tool is not to be used for purposes other than intended. Read carefully and understand instructions before using this tool.

The Miller Mid-Span Access Tool (MSAT) is used to quickly and easily access fibers in 2mm, 2.5mm and 3mm buffer tubes in a mid-span location without damage to fiber. No blade adjustment is necessary, as the factory precisely mounts the blades in the tube slitting channels, resulting in consistent and accurate slitting.

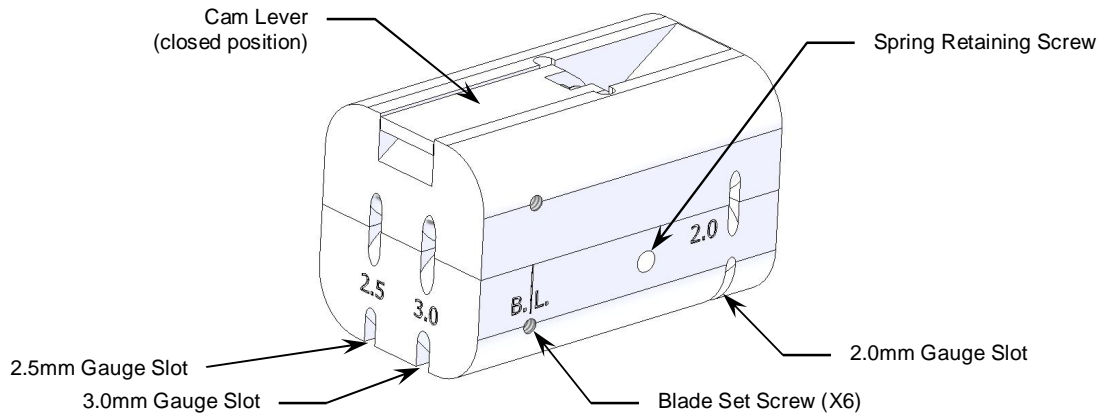

Figure 1

The tool design incorporates buffer tube size gauges on the tool body for ease of selecting proper tube slitting channel. It can slit the following tube size ranges:

Tube Outside Diameter	MSAT Slot
1.8mm to 2.2mm (.071+.086+)	2.0
2.3mm to 2.8mm (.090+.110+)	2.5
2.8mm to 3.2mm (.110+.126+)	3.0

Optimum results will be achieved the closer in size the tube is to the nominal/standard size.

SLITTING INSTRUCTIONS:

- Using the incorporated gauge slots, determine the size of the buffer tube to be slit. (Figure 1)
- Open the tool by lifting the cam lever.
- Position the tube in the appropriate channel, ensuring it is fully aligned. The blades are located at a groove mark, where indicated by B.L. This blade line is where the cut will start. (Figure 2)
- Close the tool by rotating the cam lever.
- Firmly grasp the tool and pull in the desired direction. The tool produces two cuts in the tube, 180° from each other.
- The split tube can now be separated to access the fiber. Trim the tube sections as desired.

BLADE REPLACEMENT:

- With the tool in the open position and using the supplied hex wrench, remove the spring retaining screw.
- Loosen the set screw to the appropriate blade.
- Remove the old or damaged blade.

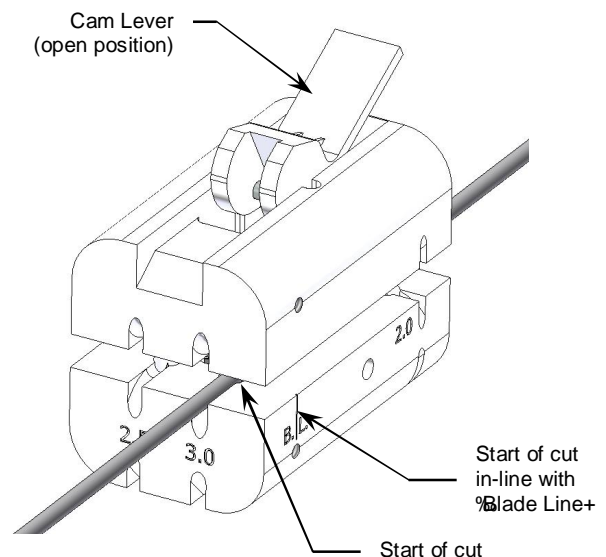

Figure 2

4. Place new blade in the blade pocket. Orient with plastic flat surface facing the screw and the blade parallel with the channel. (*Figure 3*)
5. Ensure the blade is fully bottomed out in the pocket. Secure the blade with the set screw. Do not over tighten, as this may damage the blade.
6. Place the two body halves together and replace the spring retaining screw. Care should be taken to ensure the retaining screw engages the spring.
7. Cycle the tool (open and close it) once or twice to ensure it is properly assembled.

Replacement Blade Kit: P/N 80794

Consists of two (2) blades and a 1/16+hex wrench.

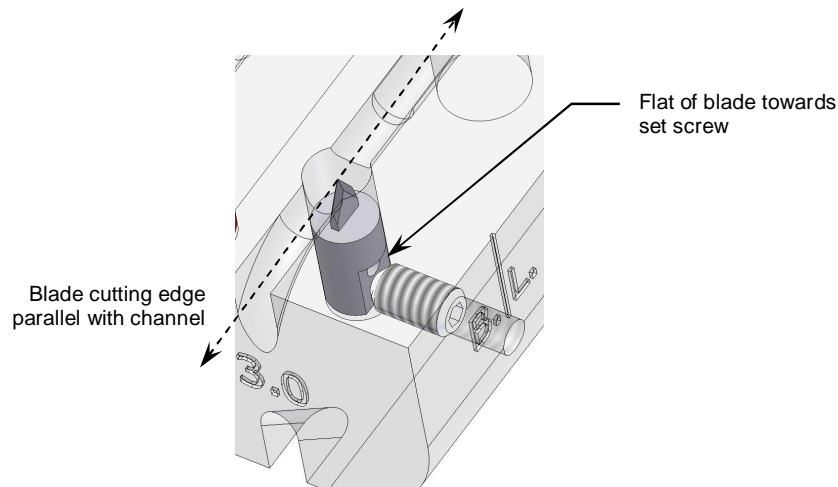

Figure 3

WARRANTY: The Ripley Company warrants that our line of tools are free of defect and fully operable at the time of shipment. The warranty is limited to the repair or replacement of any product which proves to be defective in material or workmanship, under normal use and service.



46 Nooks Hill Road, Cromwell, CT 06416 USA ~ Phone: 800-528-8665 ~ Int'l: (01) 860-635-2200
Fax: (01) 860-635-3631 ~ E-mail: info@ripley-tools.com ~ Internet: www.ripley-tools.com