



## Assembly

Before you begin, please carefully go through each phase of the entire installation instruction. Then execute them step by step. Follow site safety regulations. Wear gloves and goggles. For more information, contact your local Sales Engineer.

## Montage

Avant de commencer, lire attentivement l'ensemble des instructions de montage. Ensuite, exécuter pas à pas ces instructions. Se conformer aux réglementations de sécurité sur chantier. Porter gants et lunettes de protection. Pour toute information complémentaire, s'adresser au représentant commercial de la région.

## Montage

Bevor Sie beginnen, sollten Sie sorgfältig jede Phase der Installationsanleitung durchgehen. Danach führen Sie sie Schritt für Schritt aus. Befolgen Sie die Montagesicherheitsbestimmungen. Tragen Sie Handschuhe und wenn erforderlich Schutzbrille. Für weitere Informationen wenden Sie sich bitte an Ihren örtlichen Verkaufingenieur.

## Montage

Voordat u begint, moet u elk deel van de montageinstructies zorgvuldig doornemen. Voer ze vervolgens stap voor stap uit. Volg de veiligheidsvoorschriften voor het bouwterrein. Draag handschoenen en een veiligheidsbril. Voor meer informatie kunt u contact opnemen met uw plaatselijke, technische vertegenwoordiger.

## Montering

Før montering påbegyndes, bedes De gennemlæse hele installationsvejledningen grundigt. Derefter følges denne punkt for punkt. Lokale sikkerhedsbestemmelser på monteringsstedet skal overholdes. Handsker og beskyttelsesbriller skal bruges. Ønsker De yderligere oplysninger, bedes De henvende Dem til Deres lokale salgsgeniør.

## Assemblaggio

Prima di cominciare, vogliate esaminare minuziosamente ogni fase delle istruzioni di installazione. Quindi eseguitele passo per passo. Seguite le norme di sicurezza. L'uso di guanti e di occhiali di protezione è obbligatorio. Per ulteriori informazioni, vogliate mettervi in contatto con il Tecnico delle Vendite responsabile per la vostra zona.

## Montagem

Antes de começar recomendamos que leia as instruções para se familiarizar bem com cada fase da instalação. Em seguida, proceda à sua execução passo a passo. Siga as instruções relativas a segurança. Ponha luvas e olhos de protecção. Para mais informação, consulte o técnico de vendas mais próximo.

## Montaje

Antes de empezar, compruebe cuidadosamente las instrucciones de cada una de las fases de la instalación. Ejecute paso a paso cada fase. Siga las instrucciones de seguridad que se ajusten a la normativa local. Use guantes y gafas protectoras. Para más información consulte a su técnico local de ventas.

## Installation

Innan du börjar, gå noga igenom varje fas av monteringsanvisningen. Utför dem därefter steg för steg. Följ lokala säkerhetsföreskrifter för montering. Använd handskar och skyddsglasögon. För mer information, kontakta er lokala försäljningsingenjör.

## Kokoaminen

Ennenkuin aloitat, lue tarkoin asennusohjeiden jokainen kohta. Tee sitten kohta kohdalta niinkuin ohjeissa neuvotaan. Noudata tavanomaisia turvallisuusmääräyksiä. Käytä suojakäsineitä ja kasvosuojainta. Lisätietoja saat paikalliselta myynti-insinööriltä.

## Szerelés

Kérjük, a munka kezdése előtt gondosan tanulmányozza a szerelési utasítás valamennyi fázisát. Kérjük kövesse azt lépésről lépésre. Ügyeljen a munkavédelemi szempontokra. Használjon védőkesztyűt, és ha szükséges védőszemüveget is. További információk tekintetében kérjük, forduljon a cég helyi képviselőjéhez.

## 組立て

組立てを始める前に、各ステップごとの取り付け方法すべてを注意深くお読み下さい。それから、各々の説明通り、作業をステップごとに実施して下さい。設置場所での安全規定に従って下さい。手袋、保護メガネ（ゴーグル）を着用して下さい。尚、詳細については、お客様の地域担当セールスエンジニアまでお問い合わせ下さい。

## Сборка

Перед началом сборки следует внимательно ознакомиться со всей инструкцией по монтажу. Выполнить все операции в указанном порядке. Соблюдать общие правила техника безопасности работы. Носить перчатки и защитные очки. За дополнительной информацией обращайтесь к местному представителю нашей фирмы.

## التركيب

قبل الشروع في التركيب ترحو قراءة التعليمات الخاصة بكل مرحلة بعناية ودقة. وبعد ذلك تنفيذ هذه التعليمات الواحدة تلو الأخرى. يتم اتباع القواعد الأمنية الضرورية كارتداء القفازات ووضع نظارات الوقاية. للحصول على معلومات إضافية، اتصلو بمهندس مركز المبيعات المحلي.

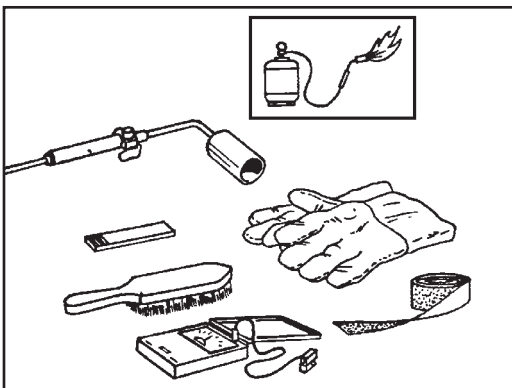

# FLEXCLAD

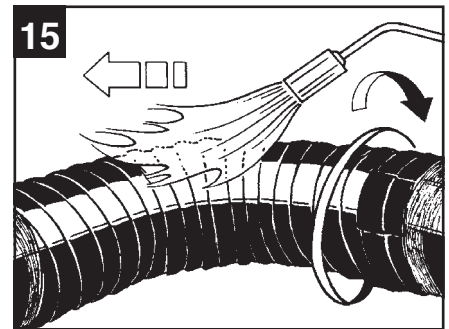
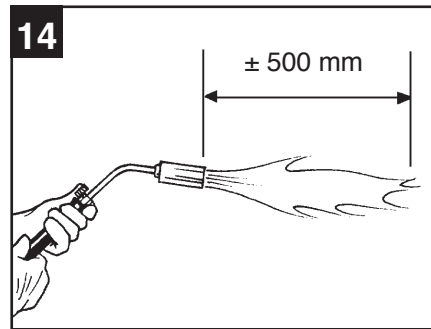
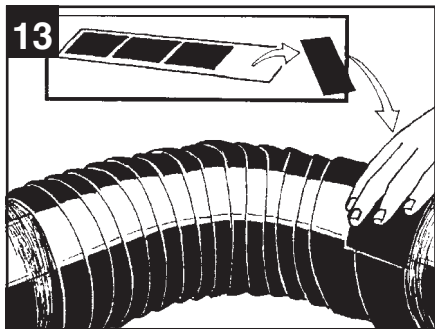
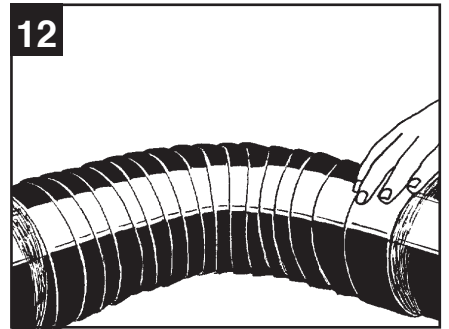
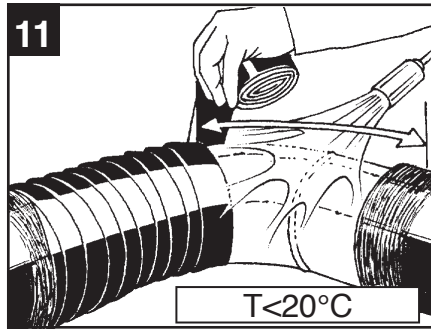
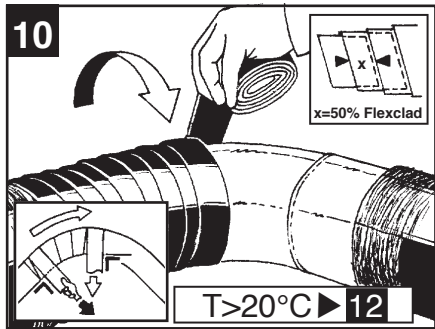
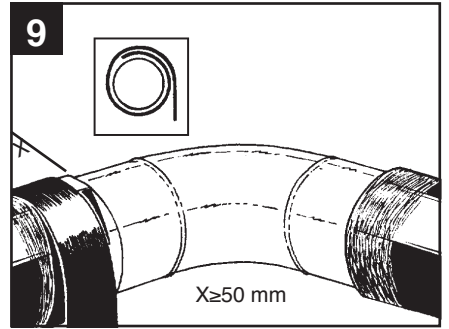
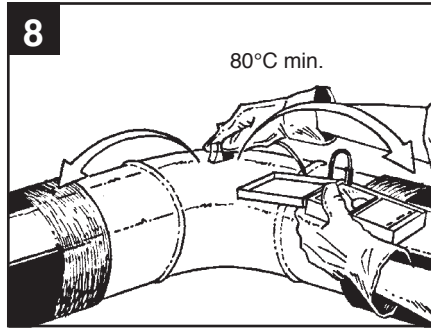
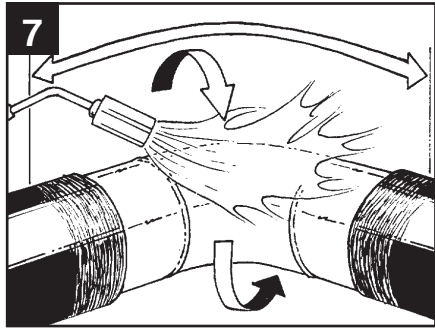
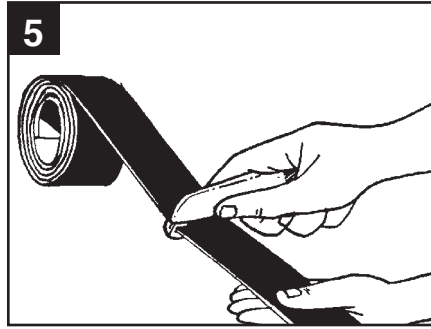
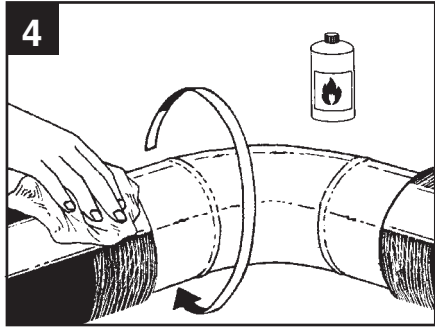
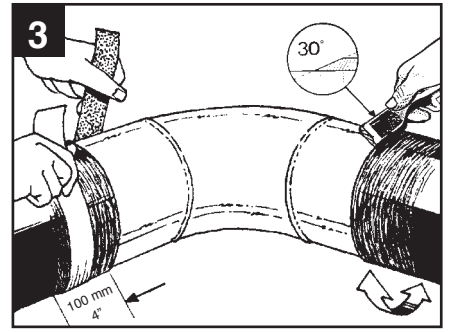
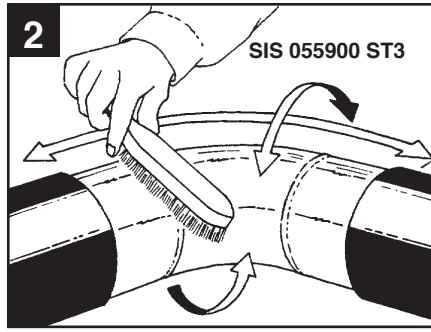
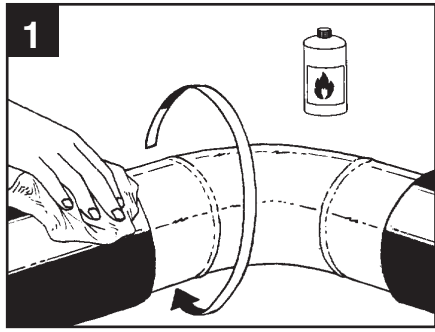

# FLEXCLAD

---

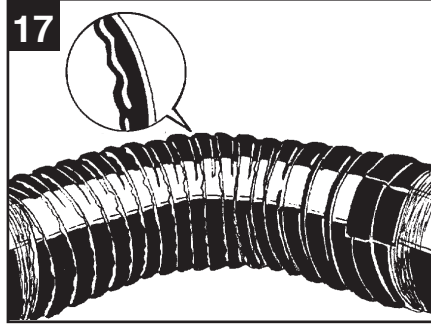
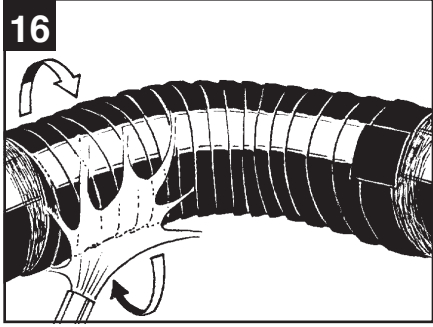

*Berry Plastics warrants that the product conforms to its chemical and physical description and is appropriate for the use stated on the technical data sheet when used in compliance with Berry Plastics written instructions. Since many installation factors are beyond the control of Berry Plastics, the user shall determine the suitability of the products for the intended use and assume all risks and liabilities in connection herewith. Berry Plastics liability is stated in the standard terms and conditions of sale. Berry Plastics makes no other warranty either expressed or implied. All information contained in this technical data sheet is to be used as a guide and is subject to change without notice. This technical data sheet supersedes all previous data sheets on this product.*



**CORROSION PROTECTION GROUP**  
[www.berrycpg.com](http://www.berrycpg.com)

Local Distributor / Representative:

For contact details of local Distributors / Representatives  
Please visit [www.berrycpg.com](http://www.berrycpg.com).

Headquarters : Berry Plastics Tapes & Coatings Division, Franklin MA, USA

**Franklin, MA, USA**

Tel: +1 508 918 1714  
US Toll Free: +1 800 248 0149  
Fax: +1 508 918 1910  
[CPG@berryplastics.com](mailto:CPG@berryplastics.com)

**Houston, TX, USA**

Tel: +1 713 676 0085  
US Toll Free: 01 888 676 7202  
Fax: +1 713 676 0086  
[CPGH@berryplastics.com](mailto:CPGH@berryplastics.com)

**Tijuana, Mexico**

Tel USA +1 858 633 9797  
Fax US: +1 858 633 9740  
Tel Mexico: +52 664 647 4397  
Fax Mexico: +52 664 647 4370  
[CPGTJ@berryplastics.com](mailto:CPGTJ@berryplastics.com)

**Westerlo, Belgium**

Tel. +32 14 722500  
Fax +32 14 722570  
[CPGE@berryplastics.com](mailto:CPGE@berryplastics.com)

**Baroda, India**

Tel: +91 2667 264721  
Fax: +91 2667 264724  
[CPGIN@berryplastics.com](mailto:CPGIN@berryplastics.com)